

Fiberoptic Sensor - Reflectance Dependent*

Model DMS-D169

These sensors provide a linear distance output with RS232 or USB communication.

For The Measurement of Distance, Displacement and Vibration
of Targets > Ø 4.3 mm

Features

- Reflectance Dependent Output
- Ø 4.29 mm Target Spot Size (0.169 inch)
- 19 mm Total Operating Range
- Ambient Light Rejection

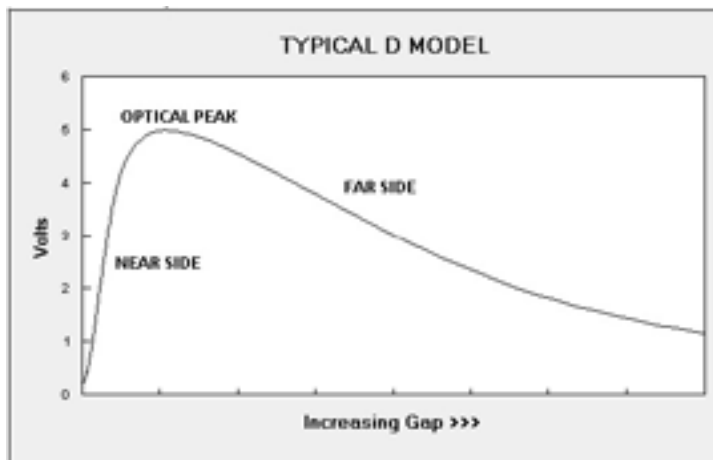
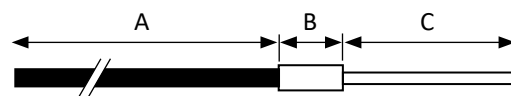
Tip & Cable Dimensions

FEATURE	mm	inch
Tip Outer Diameter, Ø C	4.75	0.187
Fiberoptic Diameter	4.29	0.169
Tip Length, C	76.2	3
Collar Length, B	15.9	0.625
Collar Diameter, Ø B	7.92	0.312
Cable Length, A	914	36
Cable Diameter, Ø A	6.86	0.27
Cable Min. Bend Radius	25.4	1

The analog input function includes NEAR and FAR SIDE regions. NEAR SIDE operation gives highest resolution with limited operating range. Operation on the FAR SIDE gives moderate resolution with much greater operating range.

*These are reflective type transducers based upon detecting the intensity of reflected light. The output is proportional to:

- distance between the sensor tip and target; and,
- the reflectivity of the target surface.

AMBIENT LIGHT REJECTION

Incoming light signals are bandpass filtered at a wavelength of 850 ± 22 nm.

DISTANCE (GAP) OUTPUT

These sensors provide a linearized distance output with RS232 or USB communication. Dynamic light signals reflected from target surfaces are converted to distance by comparing the sensor signals to gap calibration tables stored on-board the sensor.

PHILTEC®

www.philtec.com

Precision Dynamic Measurements

DMSD169:1

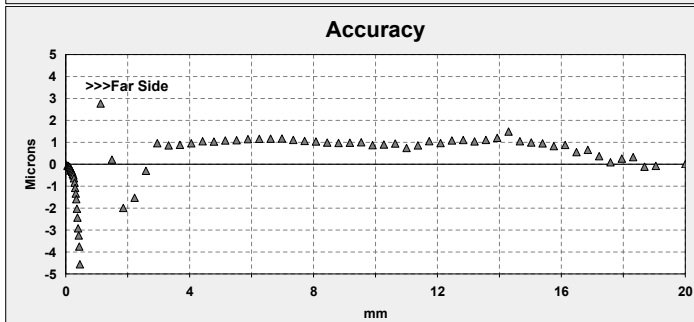
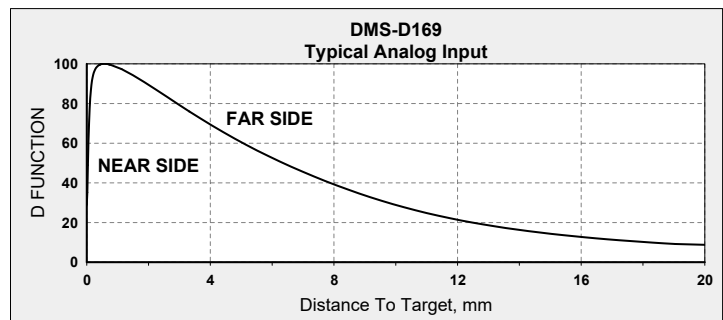
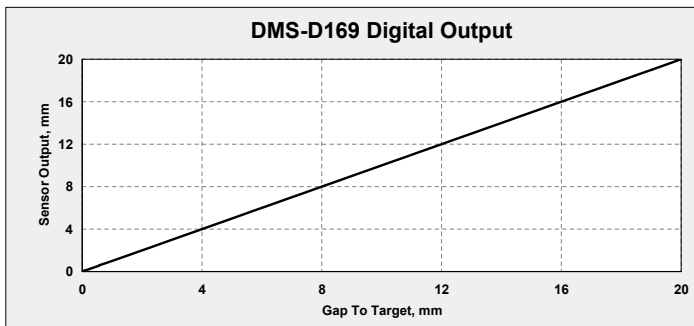

The chart above shows the analog signal input to the sensor's microprocessor. That signal is converted to a linearized distance output by comparing the input signals to gap calibration tables stored on-board the sensor. The sensor can be gapped for measurements anywhere within the sensor's total operating range. Optimum performance is achieved where the input signal has the steepest slope:

- Near Side ~50 - 300 microns
- Far Side - ~0.6 to 12 mm

Accuracy is a measure of the sensor's repeatability. It is measured at 2.5 samples/sec.

Standard Specifications, Model DMS-D169

Electronics		Fiberoptics		USB or RS232	Near Side	Far Side	
Light Source	850 nm	Light Beam Spread	30°	Total Range	400 µm	18.6 mm	
Input Voltage	+12 VDC	Cable Sheathing	PVC / Steel Monocoil	Linear Range	400 µm	18.6 mm	
Input Current	500 ma max	Tip Epoxy Outgas	0.3% @ 200°C 2.4% @ 300°C	Reflectance Resolution	0.5%		
Bandwidth	5 KHz	Tip Operating Pressure	10 bar	Temperature Resolution	0.06°C		
Iso-thermal Drift	0.05%	Tip Operating Temperature	-55 to 200°C continuous; to 300°C intermittent 1-2 hours	ADC AVG	Samples/Sec.	* Pk-Pk Resolution	* Pk-Pk Resolution
				2	5208	50 nm	1.5 µm
				16	651	40 nm	0.9 µm
				256	41	10 nm	0.20 µm
4096	2.5	5 nm	0.08 µm				
Weight	1.1 kg 2.4 lbs	Fibers	Glass				

* Pk-Pk Resolution is the smallest measurable displacement limited by the sensor's self-noise.

NOTES:

- These specifications represent best case performance where:
 - the target is flat, smooth and highly reflective
 - the sensor is perpendicular to the target
 - the sensor is gapped to its range of highest sensitivity (~mid-range)
 - fiberoptic cable lengths are standard and the cables are not connectorized
- DMS Control Software includes a data averaging filter for averaging data samples from: 2 samples (the fastest rate) to 4096 samples (highest resolution).
- Internally, the sensor continuously reads target data at a clock rate of 10,416.75 Hz.
- ADC AVG = the number of internal readings averaged before sending data out to the PC.
- Samples/Sec for any ADC AVG setting can be calculated as follows: $S/S = 10,416.75 / \text{ADC AVG}$

Three Instruments To Choose From:

- **Model mDMS-D169** ... miniDMS with RS232 output
- **Model muDMS-D169** ... miniDMS with USB output
- **Model mu2DMS-D169** ... Two Channel DMS with USB & RS232 outputs



mDMS-D169



muDMS-D169



mu2DMS-D169

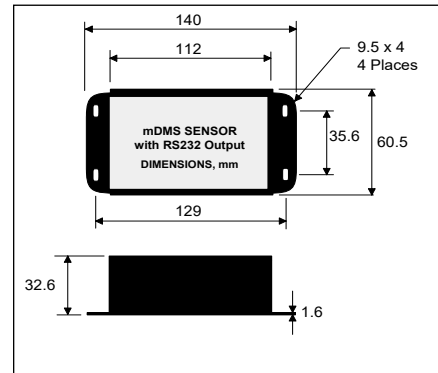

1. mDMS units include:

- Electronics with RS-232 communication

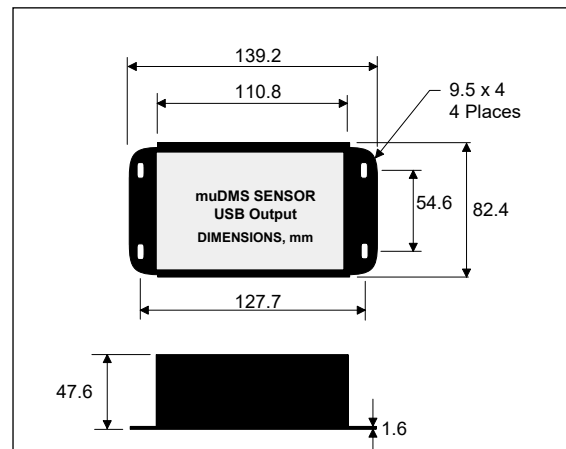

2. muDMS units include:

- Electronics with USB communication

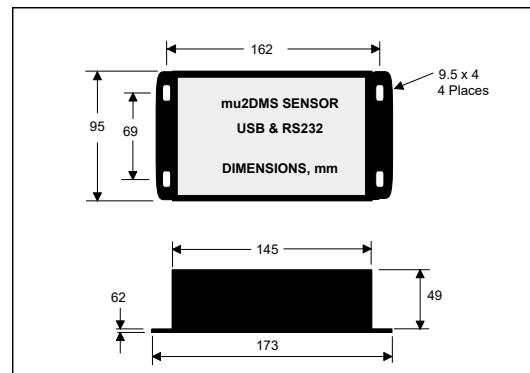

3. mu2DMS units include:

- Electronics with USB and RS232 communication

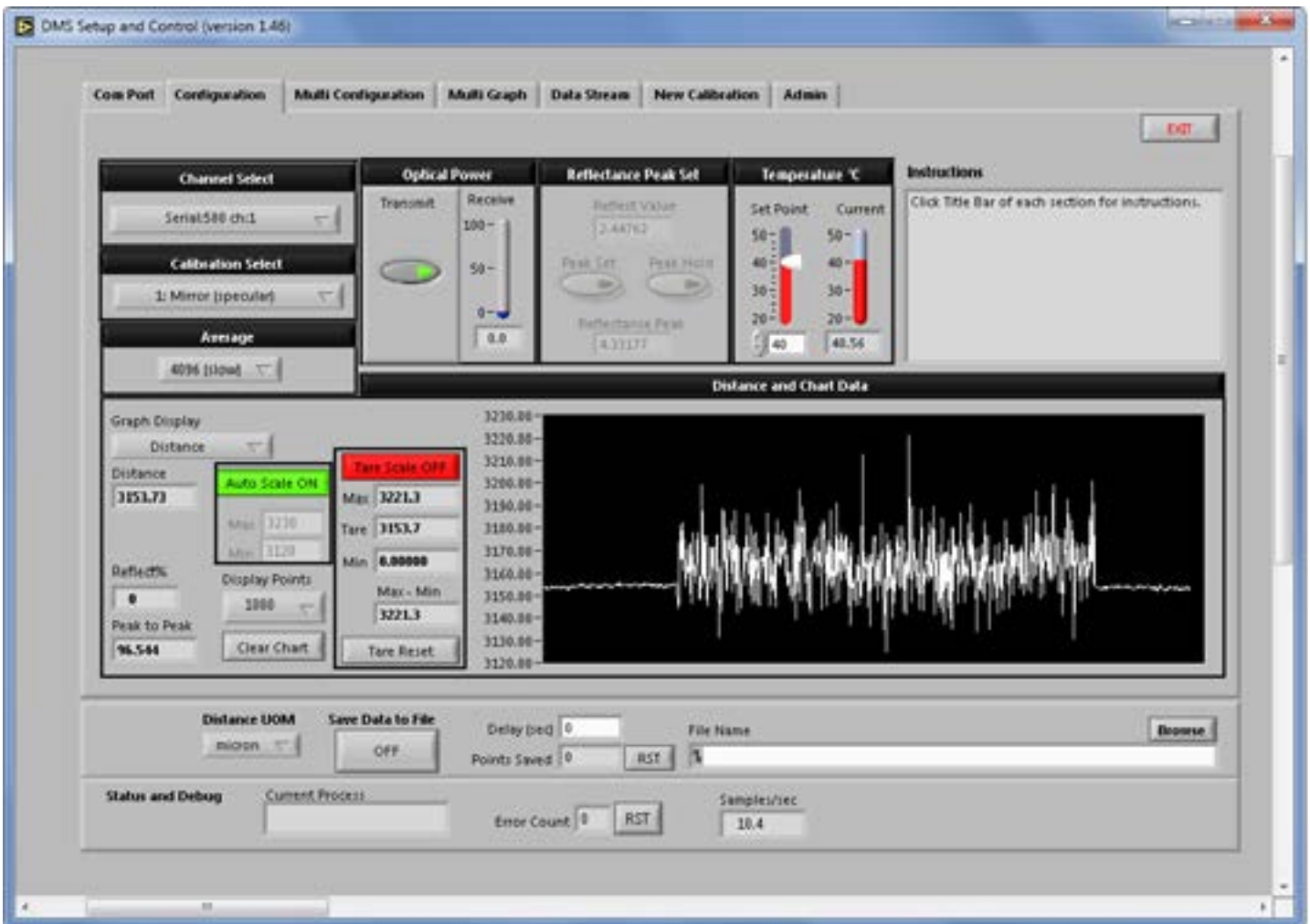

DMS SETUP and CONTROL SOFTWARE

Philtec provides freeware with every digital sensor purchase. This powerful software is a very useful tool for controlling sensors, viewing live data, and for saving data to files.

Sensors have storage capacity for 25 calibration tables. Every new sensor is provided with calibrations to:

1. A front surface mirror
2. A diffuse aluminum target

The DMS software provides means for copying and pasting sensor calibration data, as well as for creating and storing new calibration tables.

SOFTWARE & FIRMWARE UPDATES

DMS sensors can be updated remotely at any PC. The most current edition of software and firmware is posted at <http://www.philtec.com/downloads/firmware-software>. A short tutorial video link is also available there.