

Fiberoptic Displacement Sensor

Model DMS-RC225

Fiberoptic Cable & Sensor Tip - Actual Size



For The Measurement of Distance, Displacement and Vibration
for Targets > Ø 5.8 mm

Features

- 25 mm Operating Range
- Ø 5.7 Fiber Bundle (Spot Size)
- Reflectance Compensated Output
- Ambient Light Rejection



Tip & Cable Dimensions



REFLECTANCE COMPENSATION

These are reflective type transducers based upon detecting the intensity of reflected light. RC Model sensors have a pair of fiberoptic detectors in the sensor tip. Light reflected off a target follows two separate paths back to the electronics where a ratiometric calculation provides the distance measurement which is independent of varying surface reflectance; i.e., **reflectance compensated**.

AMBIENT LIGHT REJECTION

Incoming light signals are bandpass filtered at a wavelength of 850 ± 22 nm.

DISTANCE (GAP) OUTPUT

These sensors provide a **linearized distance output** with RS232 or USB communication. Dynamic light signals reflected from target surfaces are converted to distances by comparing the sensor signals to gap calibration tables stored on-board the sensor.

FEATURE	mm	inch
Tip Outer Diameter, Ø B	7.14	0.281
Fiberoptic Area	Ø 5.72	0.225
Tip Length, B	38.1	1.5
Cable Length, A	915	36
Cable Diameter, Ø A	6.86	0.270
Cable Min. Bend Radius	38	1.5

PHILTEC®

www.philtec.com

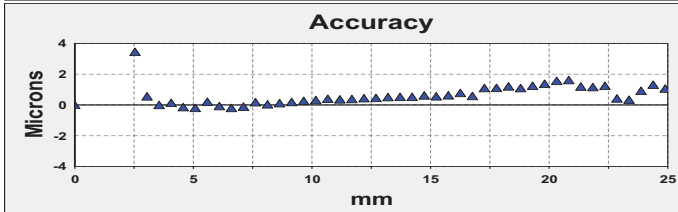
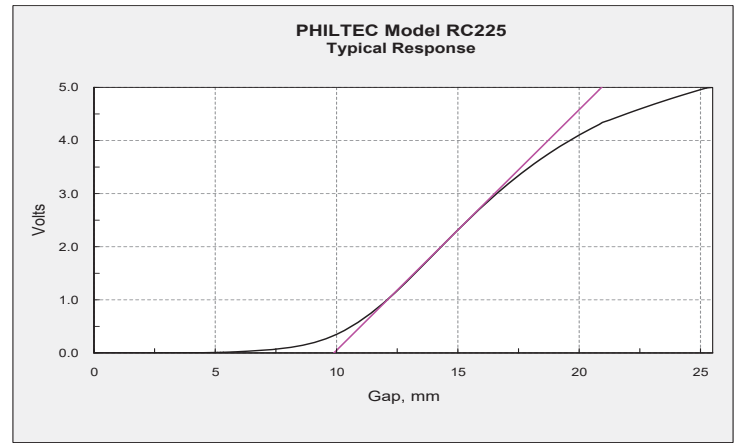
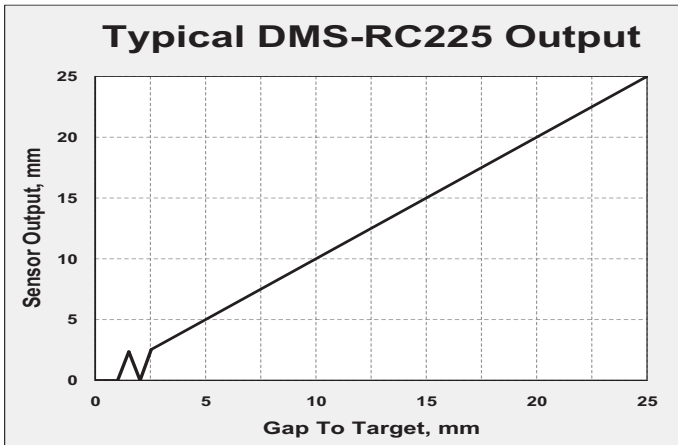

Sensor Accuracy is measured at 2.5 samples/sec.

The analog signal input to the sensor's microprocessor (shown above) is converted to a linearized distance output by comparing the input signals to gap calibration tables stored on-board the sensor. The sensor can be gapped for measurements anywhere within the sensor's total operating range. Optimum performance is achieved where the RC input signal has the steepest slope (highest sensitivity, ~9 - 18 mm).

Note: The DMS-RC225 response has a 'dead band' from 0-7 mm due to the gap between fiber bundles in the sensor tip. Reflectance Compensation is not active in that band.

Standard Specifications - DMS-RC225					
Electronics		Fiberoptics		USB or RS232	
Light Source	850 nm	Light Beam Spread	25°	Total Range	25 mm
Input Voltage	+12 VDC	Cable Sheathing	PVC over Steel Monocoil	Linear Range	7 - 25 mm
Input Current	500 ma max	Tip Epoxy Outgas	0.3% @ 200°C 2.4% @ 300°C	Reflectance Resolution	0.5%
Bandwidth	5 KHz max	Tip Operating Pressure	10 bar	Temperature Resolution	0.06°C
Iso-thermal Drift	0.05%	Tip Operating Temperature	-55 to 200°C continuous; to 300°C intermittent 1-2 hours	Resolution*	** samples/sec pk-pk
Weight	1.1 kg -2.4 lbs.	Fibers	Glass	ADC AVG = 2	5208 50 µm
				ADC AVG = 16	651 10 µm
				ADC AVG = 256	41 0.8 µm
				ADC AVG = 4096	2.5 0.4 µm

NOTES:

*These specifications represent best case performance where:

- the target is flat, smooth and highly reflective
- the sensor is perpendicular to the target
- the sensor is gapped to its range of highest sensitivity (~mid-range)
- fiberoptic cable lengths are standard and the cables are not connectorized

**DMS Control Software includes a data averaging filter for averaging data samples from: 2 samples (the fastest rate) to 4096 samples (best resolution).

Internally, the sensor continuously reads target data at a clock rate of 10416.75 Hz. ADC AVG = the number of internal readings averaged before sending data out to the PC.

Samples/Sec for any ADC AVG setting can be calculated as follows:

- S/S = 10,416.75 / ADC AVG

Three Instruments To Choose From:

- **Model mDMS-RC225** ... miniDMS with RS232 output
- **Model muDMS-RC225** ... miniDMS with USB output
- **Model mu2DMS-RC225** ... Two Channel DMS with USB & RS232 outputs



mDMS-RC225



muDMS-RC225



mu2DMS-RC225

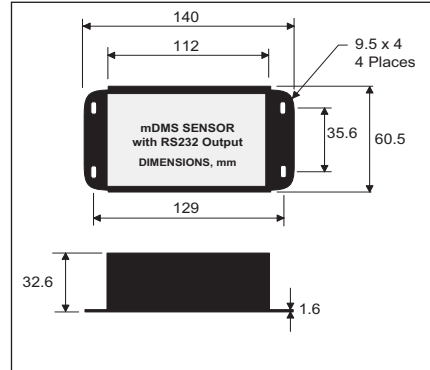

1. mDMS units include:

- Electronics with RS-232 communication

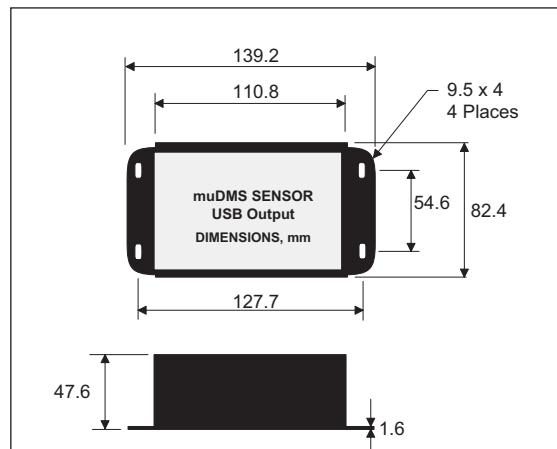

2. muDMS units include:

- Electronics with USB communication

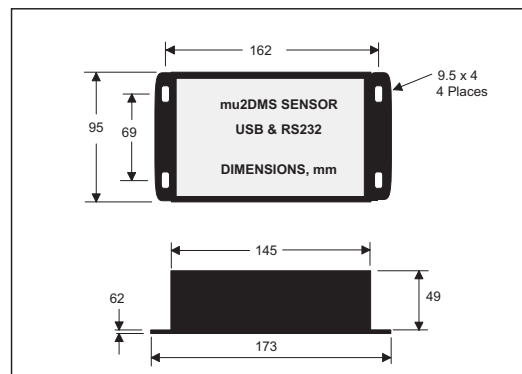

3. mu2DMS units include:

- Electronics with USB and RS232 communication

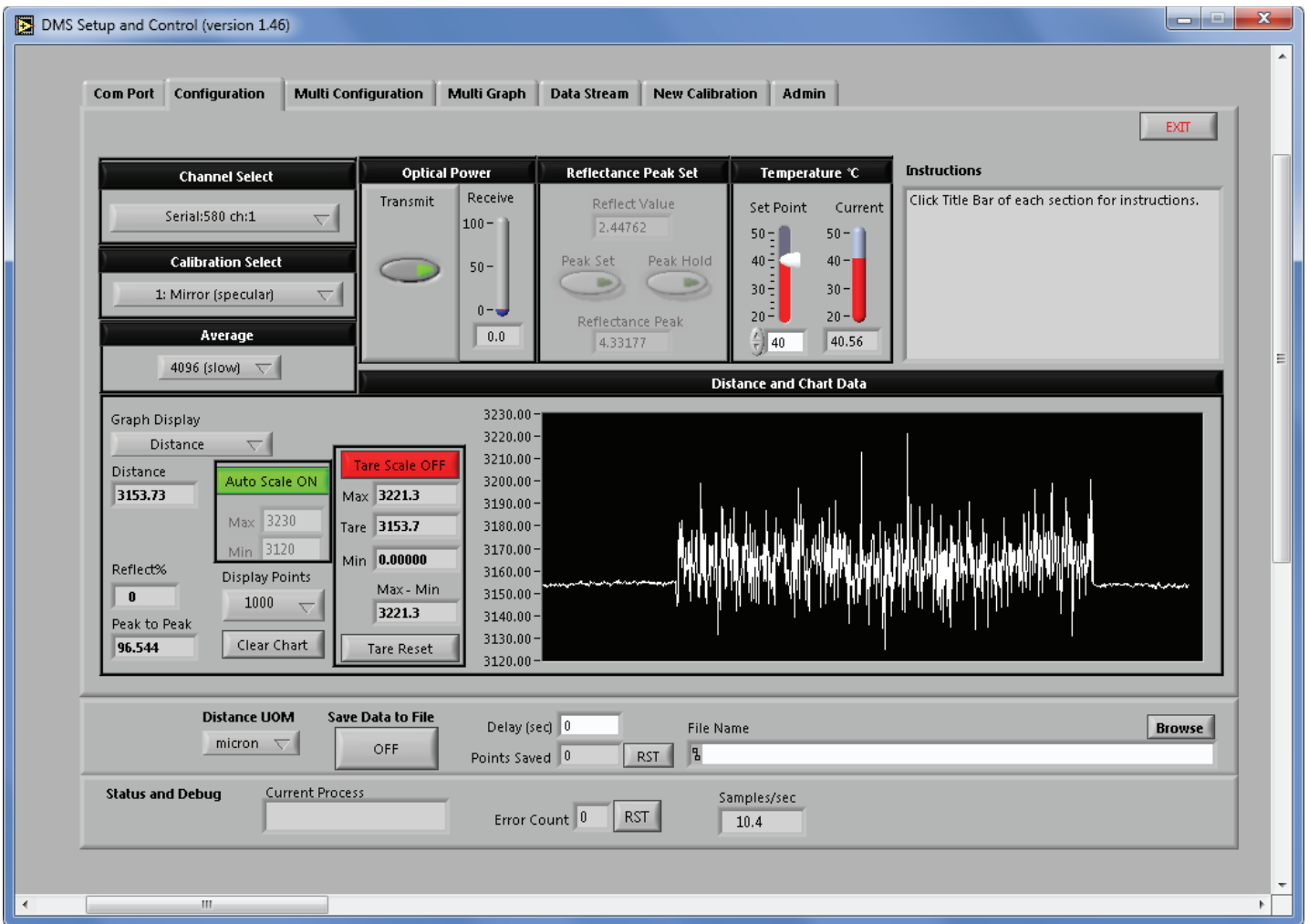

DMS SETUP and CONTROL SOFTWARE

Philtec provides freeware with every digital sensor purchase. This powerful software is a very useful tool for controlling sensors, viewing live data, and for saving data to files.

Sensors have storage capacity for 25 calibration tables. Every new sensor is provided with calibrations to:

1. A front surface mirror
2. A diffuse aluminum target

The DMS software provides means for copying and pasting sensor calibration data, as well as for creating and storing new calibration tables.

SOFTWARE & FIRMWARE UPDATES

DMS sensors can be updated remotely at any PC. The most current edition of software and firmware is posted at <http://philtec.com/downloadssupport/firmware.html>. A short tutorial video link is also available there.