

# User Manual

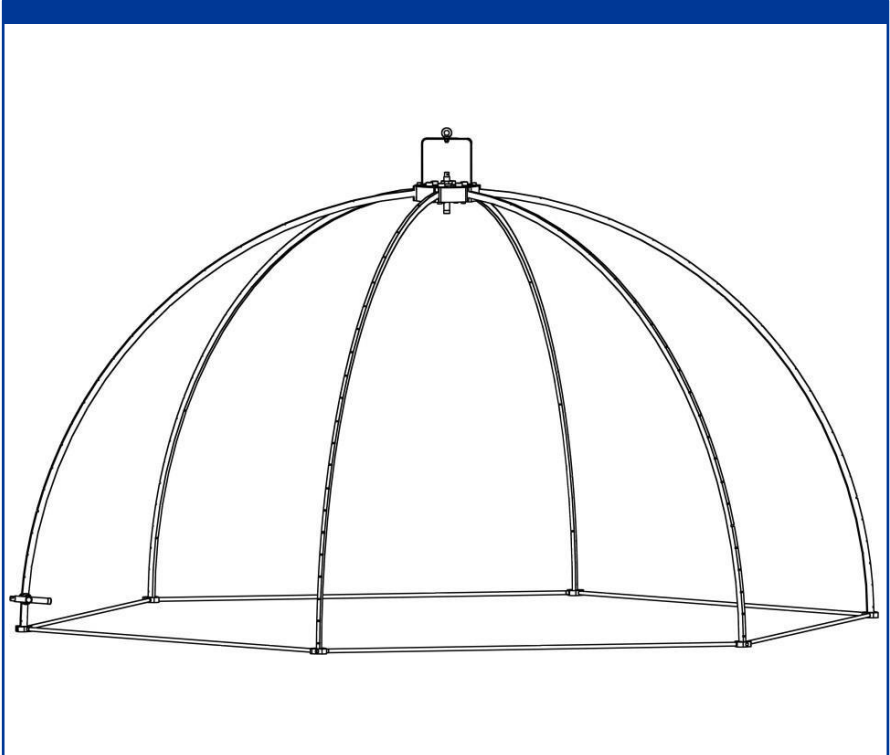

**MF710** Hemispherical Array for Sound Power

**MF720** Hemispherical Array for Sound Power

MF710/MF720 Hemispherical Array for Sound Power User Manual

BSWA-III-C021-04-P0016

v1.0

Copyright © 2016 BSWA Technology Co., Ltd.

The specification of product is subject to changes without notice

[www.bswa.com.cn](http://www.bswa.com.cn)

Sep. 2016

## Change History

Version	Date	Changes	Handle by
1.0	2016.09.01	Initial version	Zhang Baojian, Jason Qiao

**THIS MATERIAL, INCLUDING DOCUMENTATION AND ANY RELATED COMPUTER PROGRAMS, IS PROTECTED BY COPYRIGHT CONTROLLED BY BSWA. ALL RIGHTS ARE RESERVED. COPYING, INCLUDING REPRODUCING, STORING, ADAPTING OR TRANSLATING, ANY OR ALL OF THIS MATERIAL REQUIRES THE PRIOR WRITTEN CONSENT OF BSWA. THIS MATERIAL ALSO CONTAINS CONFIDENTIAL INFORMATION, WHICH MAY NOT BE DISCLOSED TO OTHERS WITHOUT THE PRIOR WRITTEN CONSENT OF BSWA.**

## Contents

Change History .....	1
Contents .....	2
1. Introduction .....	3
1.1 General Description .....	3
1.2 Features .....	3
1.3 Spectification .....	3
1.4 Packing List .....	4
2. Fixture Assembly .....	6
2.1 Overall Component .....	6
2.2 Track Pre-Assembly .....	7
2.3 Track and Central Plate Assembly .....	8
2.4 Fix Microphone with FC002 Microphone Fixing Connector .....	9
2.5 Fixing Ring .....	10
2.6 Microphone Position .....	11
2.7 Microphone Axial Position Adjustment .....	13
3. Operation Notes .....	14
3.1 Warranty .....	14
3.2 Customer Service Phone Number .....	14

## 1. Introduction

### 1.1 General Description

**MF710 / MF720** are hemispherical array designed by BSWA for sound power measurement. **MF710** meet the requirement of 10 microphone method according to GB 6882-1986, ISO 3745:1977, GB/T 18313-2001 and ISO 7779:2010. **MF720** meet the requirement of 20 microphone method according to GB/T 6882-2008, ISO 3745:2012.

The **MF710 / MF720** were designed as small, light and easy to assemble fixture. Microphone can be mounting on the hemispherical surface very quickly and accurately, so that in accordance with the standard requirements for sound power measurement becomes very easy. BSWA also provide multi-channel data acquisition device and software to working together with the fixture for sound power measurement.

### 1.2 Features

- Meet the requirement of GB/T 6882, ISO 3745, GB/T 18313, ISO 7779
- Microphone can be moving along the track to meet the 10 and 20 microphone method
- Various type microphones with 1/2 inches preamplifier could be mount
- It can be fixed on the ground or be hung installation
- Easy to assumable, light weight and compact structure, supplied with professional packing box
- Suitable for sound power measurement in laboratory and outdoor

### 1.3 Specification

Specification		
Type	MF710-XX <sup>1</sup>	MF720-XX <sup>1</sup>
Standard	GB 6882-1986, ISO 3745:1977 GB/T 18313-2001, ISO 7779:2010	GB/T 6882-2008, ISO 3745:2012
Application	10 Microphone for Sound Power	20 Microphone for Sound Power
Microphone	1/2" Microphone	
Radius	Optional: 1m / 1.5m / 2m	
Weight (only hemispherical array)	-10: 6.8kg / -15: 10.9kg / -20: 17.7kg	-10: 6.8kg / -15: 10.9kg / -20: 17.7kg
Dimension of Packing Box (mm)	-10: W1565 X H165 X D417 -15: W 2266X H165 X D566 -20: W1416 X H225 X D417	

Note 1: -XX is the radius of fixture. -10 = radius 1m, -15 = radius 1.5m, -20 = radius 2m

### 1.4 Packing List

No.	Type	Description	
<b>Standard</b>			
1	MF710 / MF720 Hemispherical Array for Sound Power	Hang Unit	1 pcs.
		Central Plate	1 pcs.
		Track	6 pcs.
		Fixing Ring	6 pcs.
2	Accessories <sup>1</sup>	All included	Screw M10*12 10 pcs
		Radius 1m	Screw M5*20 20 pcs
			Screw M6*10 4 pcs
		Radius 1.5m/2m	Screw M6*20 20 pcs
		Radius 2m	Screw M5*25 Spring gasket M5 Nut M5 50 set
All included	Wrench 1 set		
3	User Manual	Operation instruction	
4	Packing Box	Suitable for transport	
<b>Option</b>			
5	MPA201 1/2" Microphone	MF710	10 pcs.
		MF720	20 pcs.
6	FC002-X <sup>2</sup> Microphone Fixing Connector	MF710	10 pcs. Fix microphone on track.
		MF720	20 pcs. Fix microphone on track.
7	CBB020 <sup>3</sup> 20m BNC Cable	MF710	10 pcs. Connect microphone to data acquisition
		MF720	20 pcs. Connect microphone to data acquisition
<p>Note 1: Accessories include socket head wrench and screw. Supplied with several more screws to prevent loss or damage. Screw M5*25, spring gasket M5 and nut M5 are used to assemble track of array with radius 2m.</p> <p>Note 2: FC002-A used for radius 1m array, FC002-B used for radius 1.5m array, FC002-C used for radius 2m array. The microphone fixing connector cannot be universal.</p> <p>Note 3: Standard length is 20 meters. Customer can specify the length when ordering.</p>			

MF710 recommended with 10-channel data acquisition: MC38102

MF720 recommended with 20-channel data acquisition: MC38200

Software: VA-Lab BASIC + VA-Lab Power

## 2. Fixture Assembly

### 2.1 Overall Component

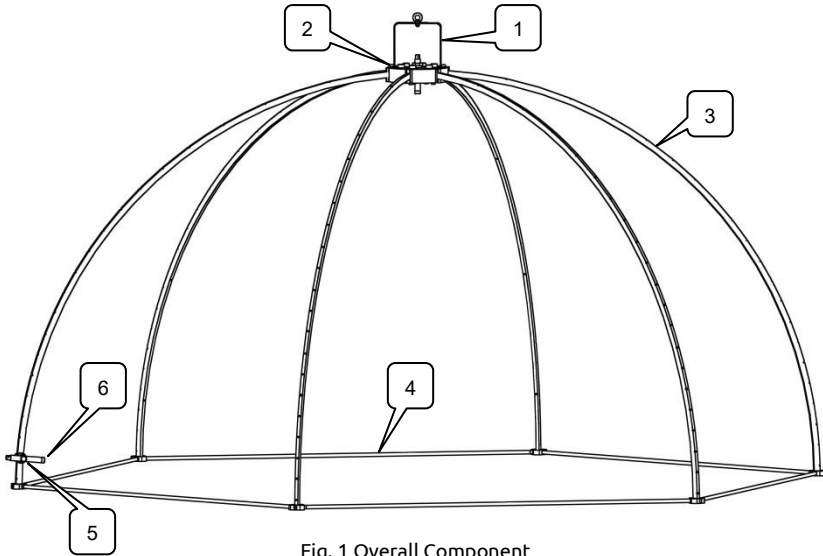
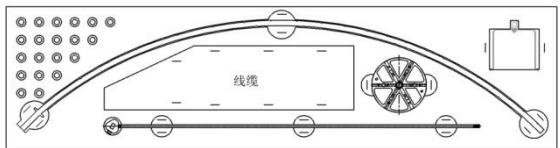
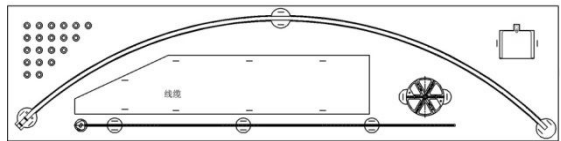

Fig. 1 Overall Component

1	Hang Unit
2	Central Plate
3	Track
4	Fixing Ring
5	FC002 Microphone Fixing Connector
6	Microphone



MF710/MF720-10



MF710/MF720-15

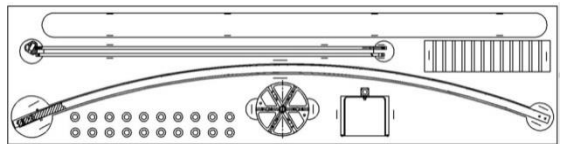

MF710/MF720-20

Fig.2 Packing Drawing



## 2.2 Track Pre-Assembly

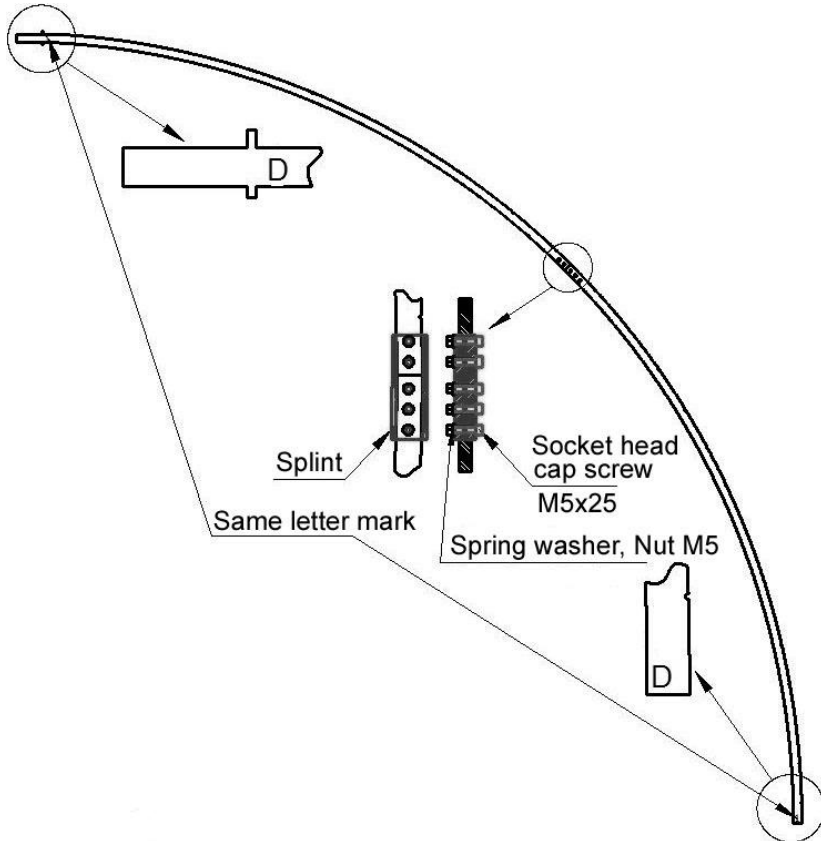

Fig.3 MF710-20 / MF720-20 Track Assembly

MF710-20 and MF720-20, which radius is 2 m, need to assemble the curved track due to it was designed to be composed of two parts. The track of radius 1m and 1.5m cannot separate so it's no need to pre-assemble.

The way to assemble is find the track marked with the same letter and connects together with splints and screws.

### 2.3 Track and Central Plate Assembly

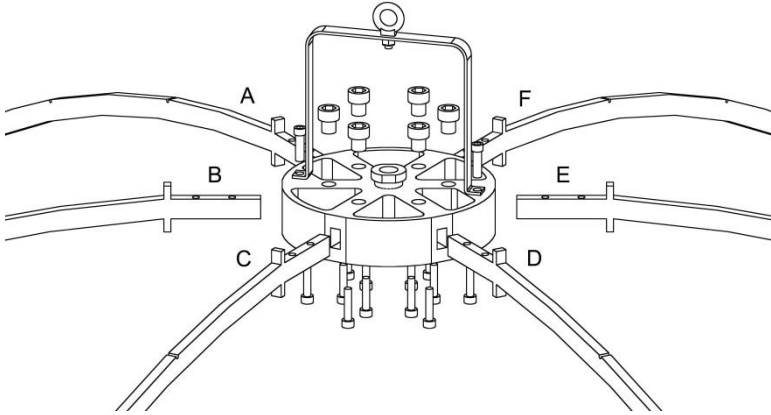

Fig.4 Mount Track to Central Plate

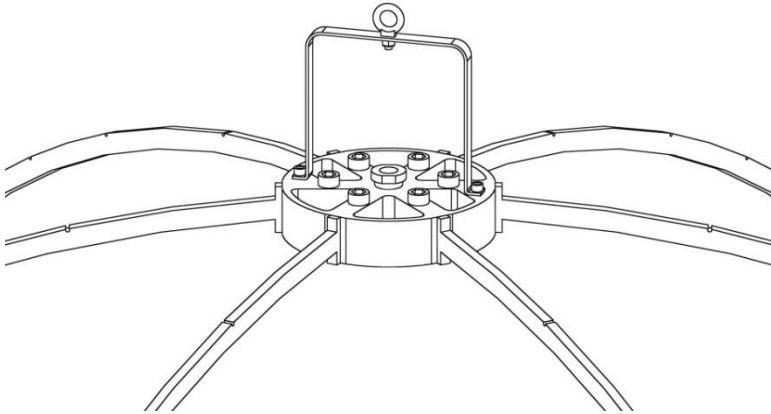

Fig.5 Assembly Finished

Connect track to the central plate as shown in Fig.4 and Fig.5. Insert the track into central plate and using a screw fastening (three screws for each track). The hang unit must be mounting firmly as shown in figure.

**Note:** The track must be installed in alphabetical order according with letter marked on the head and end of the track.

**Note:** Hang unit must be mounting firmly enough in order to avoid damage the array while lifting.

## 2.4 Fix Microphone with FC002 Microphone Fixing Connector

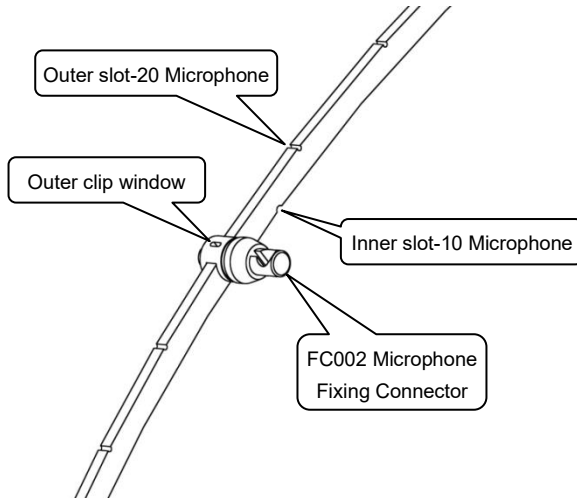

Fig. 6 Mount FC002 Microphone Fixing Connector on the Track

Microphone fixing connector installation refers to Fig.6 (all toward the same direction).

The inner and outer edges of the track are marked with slots to show the microphone position. The inner edges are slotted as 10 microphone method, and the outer edges are slotted as 20 microphone method. Each slot of microphone position has a number sign, and FC002 connector also formed with a corresponding clip window.

- Align the inner clip window and inner slot, when using 10 microphone method;
- Align the outer clip window and outer slot, when using 20 microphone method.

After determining the FC002 location, tighten the fixing nut.

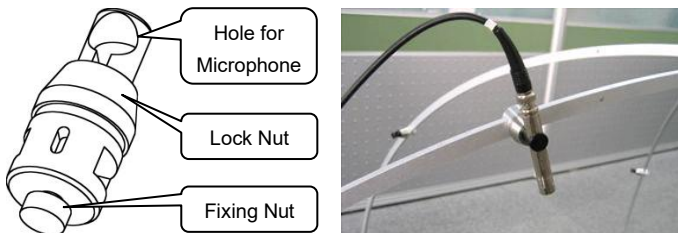

Fig.7 Mount Microphone into the FC002

Inset microphone into the FC002 and tighten the lock nut, and then connect with cables.

## 2.5 Fixing Ring

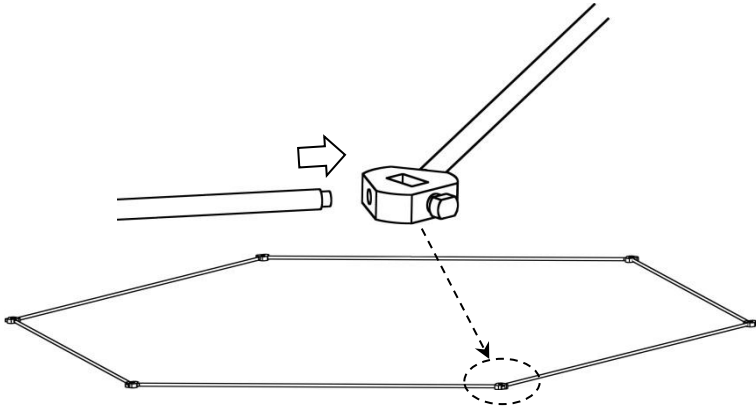

Fig.8 Fixing Ring Assembly

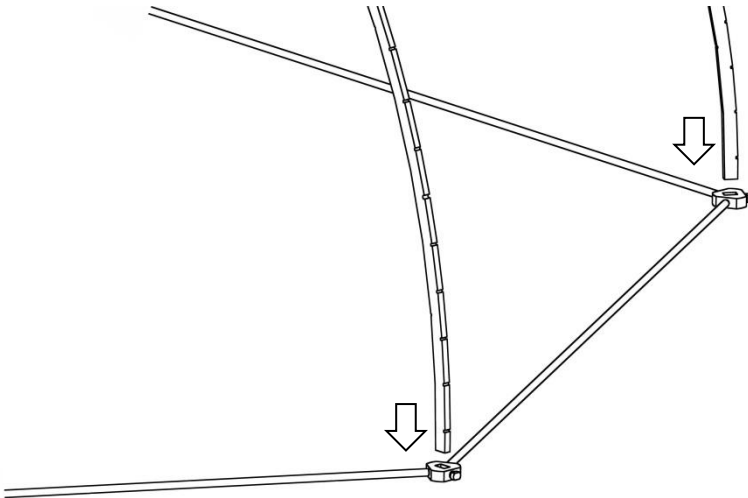

Fig.9 Connect Fixing Ring and Fixture Track

Assemble the fixing ring according to Fig.8 and laid on the ground. Then insert each end of track into the slot of fixing ring, and fastening nut to fix as shown in Fig.9.

**Note:** When lift the array with hang unit, the connection between track and fixing ring must be remove. DO NOT lift the array with fixing ring together.

## 2.6 Microphone Position

Hemispherical array support 10 and 20 microphone test method, the microphone position show in Fig.10 and Fig.11. The microphone position marked as slot on the inner and outer edge of track with number sign.

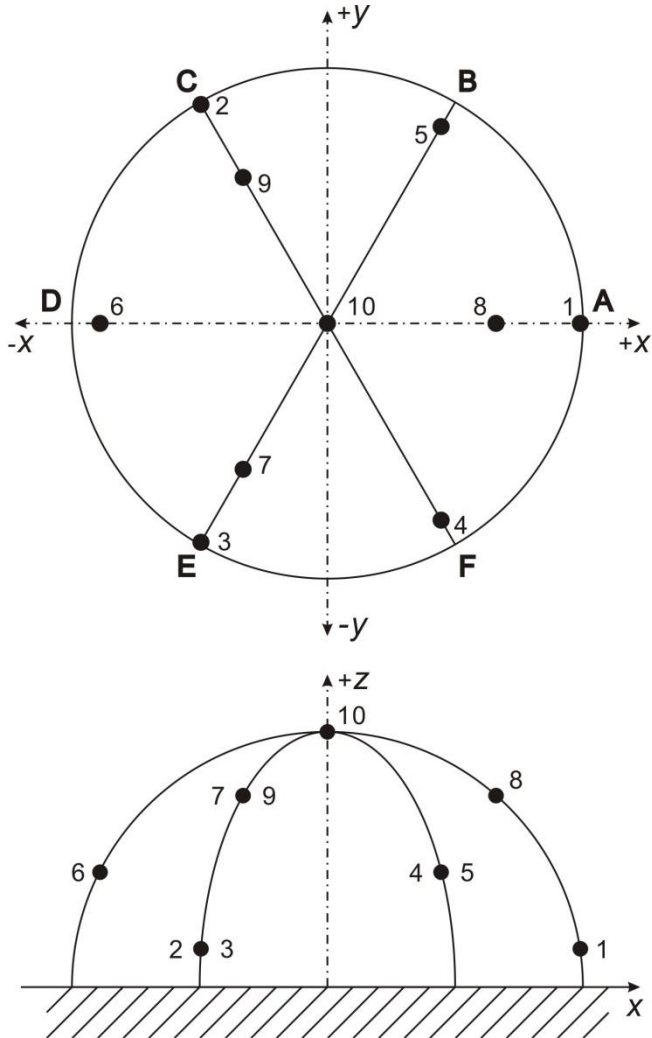
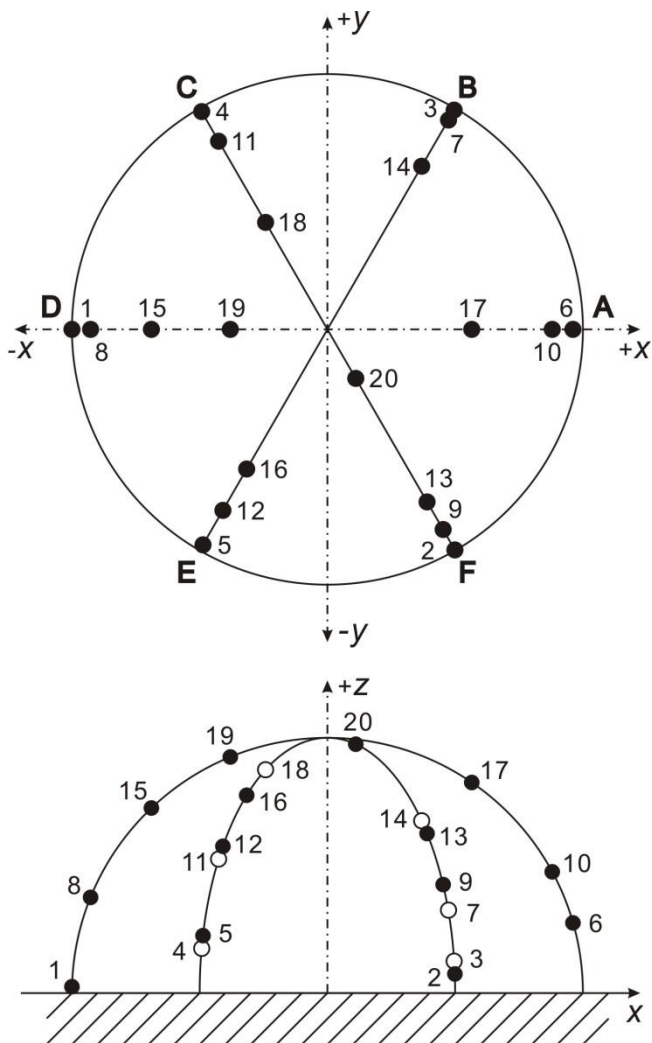

Fig.10 Microphone Position of 10 Microphone Method



- Microphone positions on the facing side
- Microphone positions on the remote side

Fig.11 Microphone Position of 20 Microphone Method

## 2.7 Microphone Axial Position Adjustment

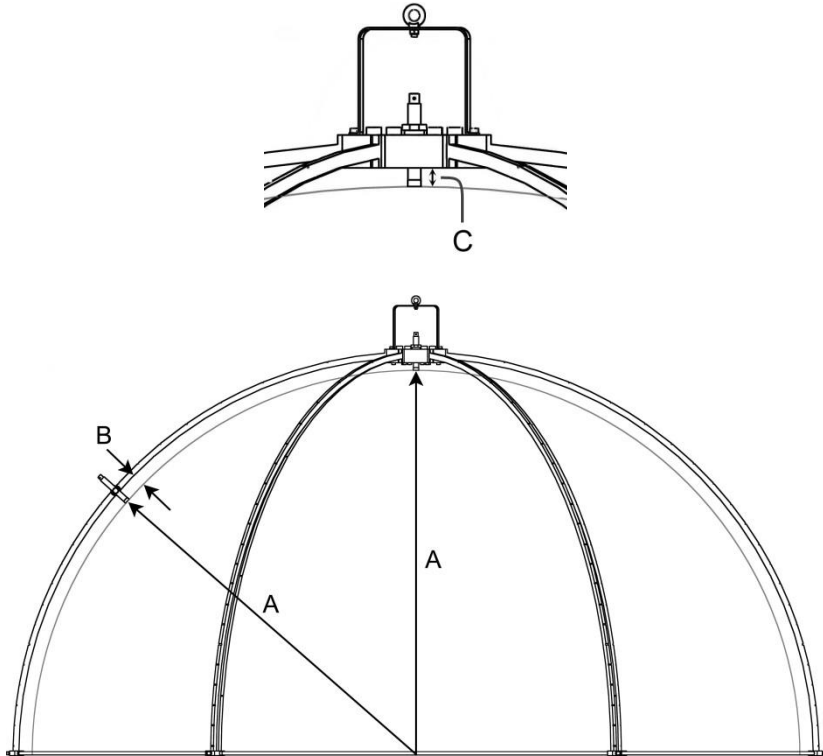

The axial position of microphone need to be adjusting careful, to ensure the distance between each microphone and device under test can meet the requirement of standard.

The axial position of microphone requirement show as below:

Type	A	B <sup>1</sup>	C <sup>1</sup>	Remark
MF710-10 / MF720-10	1000mm	35mm	22mm	Radius of 1 meter
MF710-15 / MF720-15	1500mm	25mm	12mm	Radius of 1.5 meter
MF710-20 / MF720-20	2000mm	25mm	16mm	Radius of 2 meter

Note 1: Where possible, satisfy the distance A as the highest priority. The distance B and C are for only reference.

### 3. Operation Notes

- The measurement microphone is a sensitive component, please use it careful. The environment condition of microphone required must be guaranteed. Store the microphone in the attached box which can protect it against damage from outside.
- Please follow the introduction and using step in the user manual. DO NOT drop, knock or shake the product. Any operation over the limit could damage the product.

#### 3.1 Warranty

BSWA can provide warranty service during the warranty period. The component could be replaced according to the determination of BSWA to solve the issue caused by materials, design or manufacture.

Please refer to the product warranty promise in sales contract. Do not try to open or repair the device by customer. Any unauthorized behavior will result in loss warranty of this product

#### 3.2 Customer Service Phone Number

Please do not hesitate to contact us for any issue:

Customer Service Phone Number:	+86-10-51285118 (workday 9:00~17:00)
Sales Service Phone Number:	Please visit BSWA website <a href="http://www.bswa-tech.com">www.bswa-tech.com</a> to find the sales number of your region.





## **BSWA Technology Co., Ltd.**



---

Room 1003, North Ring Center, No.18 Yumin Road,  
Xicheng District, Beijing 100029, China  
Tel: 86-10-5128 5118  
Fax: 86-10-8225 1626  
E-mail: [info@bswa-tech.com](mailto:info@bswa-tech.com)  
URL: [www.bswa-tech.com](http://www.bswa-tech.com)

*2016 BSWA*